

A metering system for delivering and metering two combinable and cooperatable liquids, in predetermined ratios in order to enable ultimate combining of such liquids or the fluids. The apparatus comprises a first discrete valve mechanism which is capable of receiving a first fluid from a source and a cooperating first discrete metering mechanism; a pumping mechanism for receiving the fluid from and directing fluid to this first valve mechanism. The apparatus also comprises a second discrete valve mechanism capable of receiving a second fluid from a source and an associated second discrete metering mechanism; a pumping mechanism for receiving fluid from and directing fluid to this valve mechanism. An actuating device operatively connects the first and second valve mechanisms and the first and second metering mechanisms in order to enable the first metering mechanism to pump the first fluid to and from the first valve mechanism and the second fluid to and from the second valve mechanism. The valve mechanisms are capable of metering the first and second fluids in proper predetermined amounts. The fluids may be combined at a mixing member as for example, a mixing gun.

US 4304574.

**HEATING SYSTEM FOR FLUIDIZED
BED GAS GENERATOR.**

Guenter Buchner, Johannes Alkemper, Rainer Deurfeld, Heinz Gaessler, Meerbusch Federal Republic of Germany. assigned to Mannesmannrhren-Werke AG.

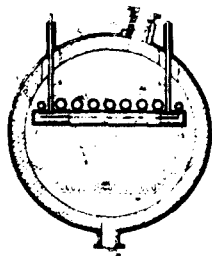

The retort chamber for generating gas by applying hot steam to coal in a fluidized bed is heated by meandering tubes, dipping into the bed, and being suspended from long, hollow boxes which, in turn, are particularly suspended in the retort chamber. The boxes support also manifold tubes connected to the heating tubes and being further connected to a heating fluid feed and distribution as well as a collecting and discharge system.

US 4304659.

**METHOD FOR CONTROLLING
REGENERATOR TEMPERATURE IN
A FLUIDIZED CATALYTIC
CRACKING PROCESS.**

Roy E. Pratt, William R Menzies III, Leonce F Castagnos Jr, Port Neches TX. assigned to Texaco, Inc.

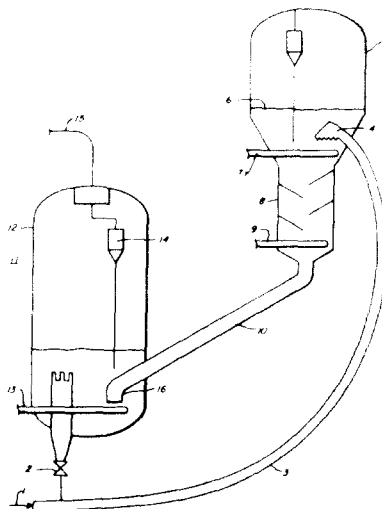

An improved method for controlling the fluidized dense catalyst phase temperature in the regeneration zone of a fluid catalytic cracking unit. In this method, the level of the fluidized catalyst bed above the riser discharge in the reaction vessel is adjusted in response to a change detected in the temperature of the fluidized dense catalyst phase of the regeneration zone. Adjustment of the catalyst bed level in the reaction zone affects the coke laydown on the catalyst in the reac-